

NOJA POWER[®]

OSM38

PRODUCT GUIDE

OSM AUTOMATIC
CIRCUIT RECLOSER
38kV MODEL



INTRODUCTION

The OSM38 automatic circuit reclosers are designed for use on overhead distribution lines as well as distribution substation applications for voltage classes up to 38kV.

The 300 series tanks are manufactured from stainless steel and powder coated a light grey colour.

The product is supplied complete with an RC10 control and communications cubicle. The RC10 control cubicle is a microprocessor based controller that provides all the protection, data logging and communications functions in a single device. The OSM has been designed for use as a stand alone device that is easily integrated into distribution automation and remote control schemes using the in-built communications capability.

The product has been extensively type tested by independent laboratories to ensure long life and reliability under the harshest environmental conditions. The OSM automatic circuit recloser is the only solid di-electric insulated recloser to provide controlled arc fault venting and independent testing provides verification of this important safety feature.



OSM recloser and RC10 Control and Communications Cubicle

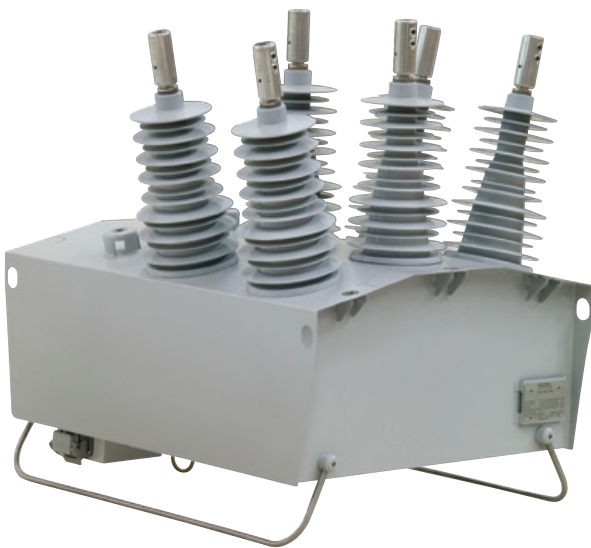

OSM38 Autorecloser

The product uses technology developed and refined over the last decade and follows on from the successful 200 Series model.

The in-built user configurable distribution automation functionality can be used with or without a communications system and will reduce outage time and increase profitability in your network.

OVERVIEW

The OSM automatic circuit reclosers incorporate vacuum interrupters inside an aromatic epoxy resin housing within an arc vented stainless steel tank. This ensures the maximum in life and reliability with a fully insulated arrangement inside the long life housing.

Voltage is measured on all six (6) bushings using capacitively coupled carbon fibre screens. Current is measured on all three (3) phases using current transformers.

The recloser mechanism is operated by three (3) separate magnetic actuators, one per phase. These magnetic actuators are mechanically interlocked to guarantee correct three (3) phase operation. The device is latched in the closed position by magnetic latching. Each magnetic actuator uses a single coil.

The recloser can be mechanically tripped using the yellow mechanical hook stick operated lever in the base of the tank.

The device Open/Close indication, also located in the base of the tank, uses a green 'O' to designate contacts are open and a red 'I' to designate contacts closed.

The status of the recloser is also reflected by a microswitch connected to the control electronics.

The electronic circuit board that provides CT shorting when the control cable is disconnected has no active elements which dramatically improves impulse immunity.

The main circuit bushings are manufactured from aromatic epoxy resin and have a silicone rubber bushing boot providing the required creepage distance.

The magnetic actuators are operated from stored energy charged capacitors located in the RC10 control cubicle. There is a rating plate located in the base of the tank that provides tank rating details in accordance with the requirements of ANSI C37.60. There is an earthing point on the side of the tank.

The 300 Series OSM is supplied with tin plated brass cable connectors on each bushing. The cable connectors can be supplied in the form of tunnel terminals to suit cable up to 260mm² or 2 hole NEMA cable palms.

The cross sectional diagram below details the OSM tank configuration and main components.

- 1. Vacuum interrupter
- 2. Push rod - insulating
- 3. Actuator
- 4. Epoxy housing
- 5. Silicone bushing extension
- 6. Terminal
- 7. Tank
- 8. Auxiliary switches

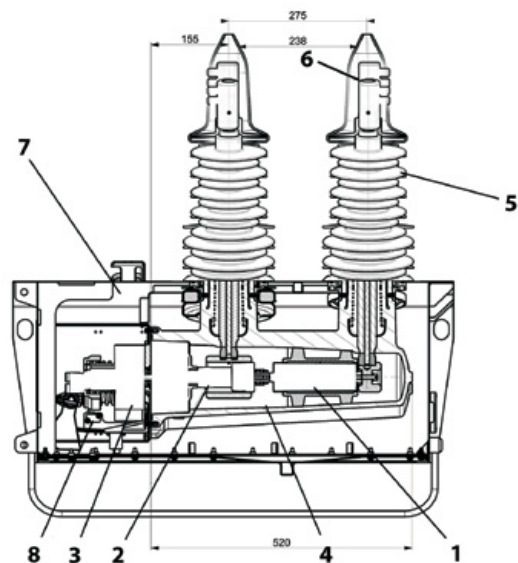
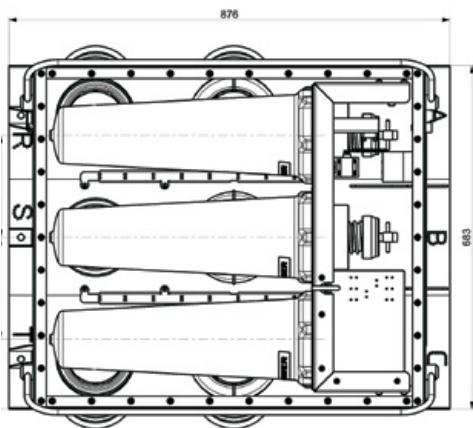

RC10 CONTROL & COMMUNICATIONS CUBICLE

The RC10 control and communications cubicle is a microprocessor based controller that provides a directional overcurrent, earth fault and sensitive earth fault relay, auto reclosing relay, instantaneous metering, event log, demand logger and remote terminal unit (RTU) for remote control in a single package.

The operator control panel is provided with a large backlit LCD display and keypad to provide local control functions.

The control cubicle has three (3) main modules:

- The operator panel module which provides the man machine interface.
- The Switchgear Interface Module (SIM) which provides the power supply battery charger and incorporates the capacitors that provide the tripping and closing energy to the OSM tank.
- The Relay module which provides the main microprocessor and DSP functionality.

Temperature compensated float charging is provided to the sealed lead acid batteries located in the RC10 control cubicle.

There is space provided inside the control cubicle to install any communications equipment to be connected to the inbuilt RTU or I/O module.

The equipment has been designed for the RC10 control cubicle to operate over a temperature range of -40 to +55°C inside the IP65 sealed enclosure.

The cubicle is constructed out of powder coated stainless steel for a long, maintenance free lifetime.



RC10 Control & Communications Cubicle



IP65/NEMA 4 Vandal proof cable housing

The roof features a ceramic based insulating coating that provides a 16°C reduction in internal temperature when the cubicle is exposed to 1.1kW of solar radiation.

The entry point for the control cable is housed within a vandal-proof enclosure and the cubicle door has a three point handle locking mechanism making it extremely difficult to break into.

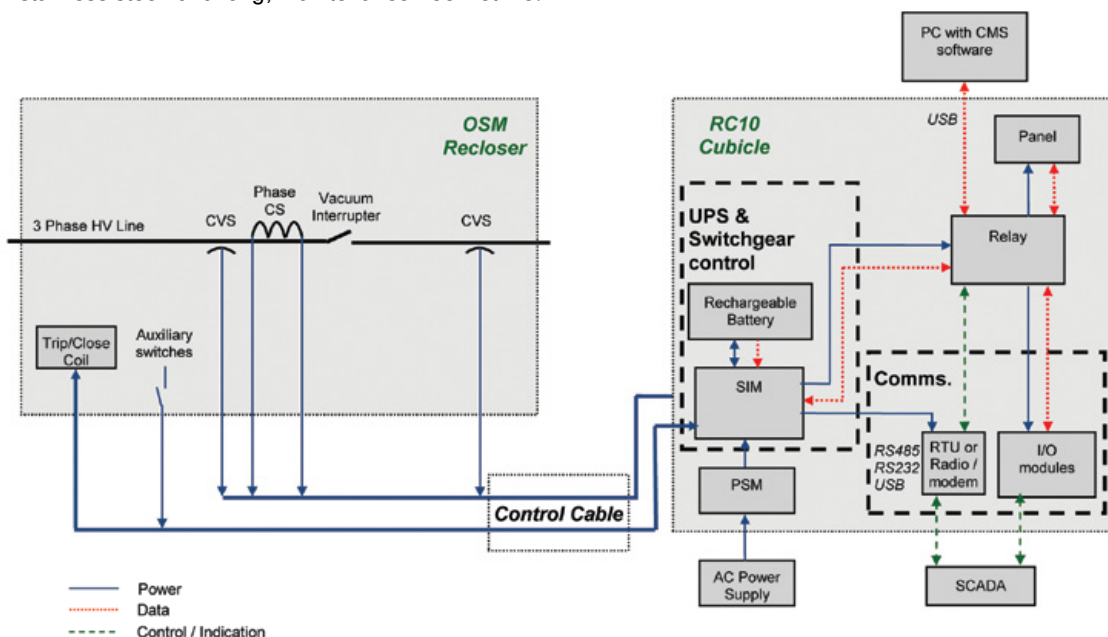

PROTECTION

- 4 Independent Protection Groups
 - Directional over current and earth fault protection
 - Current Setting Range 10–1280A
 - Setting Resolution 1A
 - Inverse Time Protection
 - Independent Curve Selection for Forward & Reverse Direction
 - 4 x IEC255 Curves
 - 8 x ANSI Curves
 - 2 x User Defined Curves
 - 42 x Custom Curves
 - Definite Time Protection
 - 0–120 seconds
 - Time Resolution 0.01 seconds
 - High set Instantaneous element
 - Directional Sensitive Earth Fault Protection
 - Current Setting Range 4–80A
 - 1–80A option available
 - Setting Resolution 1A
 - Definite Time 0–120 seconds
 - Time Resolution 0.01 seconds
 - Voltage Protection Element
 - Phase undervoltage balanced element (UV1)
 - 3 phase load shedding
 - Multiplier setting range: 0.6–1 of system voltage
 - Multiplier setting resolution: 0.01
 - Trip time range: 0–180 sec
 - Trip time setting resolution: 0.01 sec
 - Phase-to-Phase Undervoltage Element (UV2)
 - Multiplier setting range: 0.6–1 of system voltage
 - Multiplier setting resolution: 0.01
 - Trip time range: 0–180 sec
 - Trip time setting resolution: 0.01 sec
 - Loss of Supply (UV3)
 - Trip time range: 0–180 sec
 - Trip time setting resolution: 0.01 sec
 - Reclose time: 0–180 sec
 - Reclose time resolution: 0.01 sec
 - Phase (OV1) & Line-to-Line (OV2) Over Voltage
 - Trip time range: 0–180 sec
 - Multiplier Setting Range: 1.00 –1.20
 - Frequency Protection Element
 - Under Frequency (UF) Pickup Range: 46–50Hz (50Hz system), 55–60Hz (60Hz system)
 - Over Frequency (OF) Pickup Range: 50–55Hz (50Hz system), 60–65Hz (60Hz system)
 - Frequency settings resolution: 0.01Hz
 - Trip time range: 0–120 sec
 - Trip time setting resolution: 0.01 sec
 - Voltage reclose control with automatic back feed restoration provides loop automation functionality.



Local Control Panel

- Zone Sequence Co-ordination
- Cold Load Pickup
 - Cold load time ramp up: 1–400 min
 - Cold load time ramp down: 0–60 min
 - Cold load time resolution: 1 min
 - Cold load multiplier: 1–5 times pickup current
 - Cold load multiplier resolution: 0.1
- Inrush Restraint
- Inrush time: 0.01–10 sec
 - Inrush time resolution: 0.01 sec
 - Inrush multiplier: 1–20
 - Inrush multiplier resolution: 0.1
- Temporary Time Addition
 - Provides a stepped time delay to automatically isolate faulted sections in a feeder or correct grading of devices in series.
- Duty Cycle
 - 0–0.1sec–CO–1sec–CO–1sec–CO–60sec recovery time
- Reclosing Times
 - 1st reclosing time range 0.1 – 180 seconds
 - 2nd reclosing time range 1 – 180 seconds
 - 3rd reclosing time range 1 – 180 seconds
 - Setting resolution 0.01 seconds
- Auto Reclose
 - User configurable 1–4 trips to lockout, independently settable for overcurrent earth fault, sensitive earth fault and voltage protection.
- Live Line Function & Hot Line Tag Function

MEASUREMENT

Voltage is measured on all six (6) bushings and current is measured on all three (3) phases of the OSM recloser using capacitively coupled voltage sensors and current transformers.

Phase to Earth Voltage:
Range 0.3 - 22.0kV, Accuracy $\pm 1\%$ or $\pm 0.1kV$

Phase to Phase Voltage:
Range 0.5 - 38.0kV, Accuracy $\pm 2\%$ or $\pm 0.1kV$

Phase Current:
Range 0 - 630A, Accuracy $\pm 1\%$ or $\pm 4A$

Residual Current:
Range 0 - 100A, Accuracy $\pm 5\%$ or $\pm 0.5A$

Active, Reactive and Total Power:
Range 40 - 630A, 4.5 - 38kV, Accuracy $\pm 2\%$

Single and Three Phase Active, Reactive and Total Power:
Range 0 - 30,000 kW/kVAR/kVA, Accuracy $\pm 2\%$

Frequency:
Range 46-55Hz, 55-65Hz
Accuracy at $dF/dT < 0.2Hz/s$: $\pm 0.025Hz$

Range 46-55Hz, 55-65Hz
Accuracy at $dF/dT < 0.5Hz/s$: $\pm 0.05Hz$

Power Factor:
Range 0-1, Accuracy ± 0.02

EVENT LOG

The RC10 control provides two separate event logs time and date stamped to a 0.01 sec resolution.

The first is viewable from the LCD display and provides critical operations data for the linesman. It includes close/open operations, fault types, phase and peak level of fault current.

The second is viewable by PC upload using CMS. It provides a full log of all operational history including setting changes, operations and fault history.

The fault history logs include 50 cycles of pre-trip history to allow analysis of the fault propagation.

LOAD PROFILE LOG

The Load Profile is logged with a user configured integration period of either 1, 5, 10, 15, 30, 60 and 120 minutes.

The following parameters are logged separately for both positive and negative power flow:

- 3 phase, Voltage, Current & Frequency
- 3 phase kW, kVA and kVAR
- 1 phase kW, kVA and kVAR for each phase and many others

Up to 10000 events can be stored in the memory which corresponds to a 417 day, 60 minute, integration period.

CMS can be used to upload and plot the data.

REMOTE CONTROL

A USB front panel interface is provided to connect to a PC running CMS. This provides full settings and data management facilities. An RS232 RTU interface offering 300-19.2k & 3xUSB port baud, full and half duplex modes, is provided to connect to remote control systems. DNP3 communications protocols are provided in the standard product combined with our ability to engineer new protocols to meet specified customer requests.

The control cubicle has space to mount a radio or modem. The onboard radio power supply is rated at 12V 20W continuous duty, 30 watts 50% duty cycle.

I/O modules with eight (8) user configurable inputs and eight (8) user configurable outputs can be ordered as options in the RC10 control. Up to two I/O modules can be fitted extending this to sixteen inputs and sixteen outputs. Logical configures 3 x Inputs are sanitare.

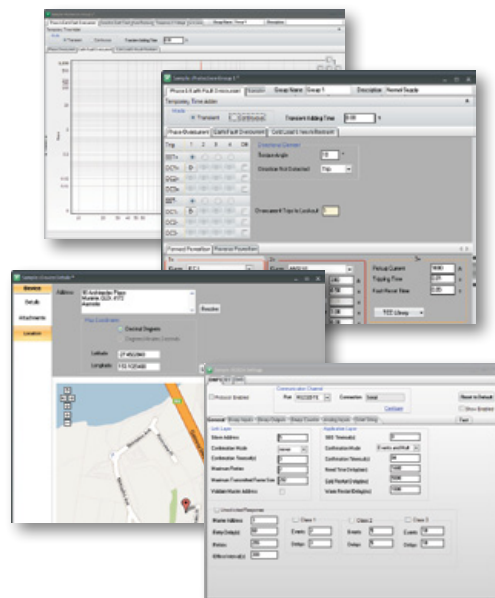

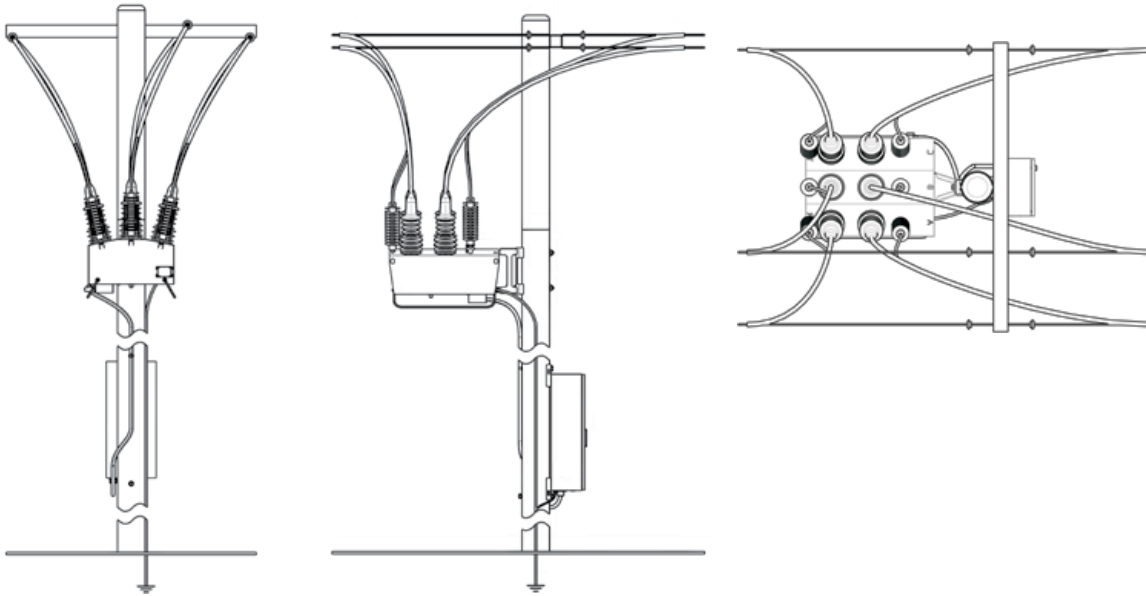

Typical Pole Mounting Arrangement

Earthing should be in accordance with the technical manual. Earthing required is a main earth bond from the tank to ground and a tee-off to the RC10 control cubicle from this main earth bond. Minimum 35mm² earth cable should be used.

Each HV terminal on the OSM 300 series has a tin-plated brass connector at the end with options for cable connection as follows:
A Tunnel terminal arrangement suitable for cable sizes from 40mm² to 260mm². Cables are secured in the connector with two hexagon socket screws.

Two hole cable palms with NEMA spacing. The cable palms are supplied with two (2) M12x25mm stainless steel bolts together with flat and spring washers.

Pole mounting brackets and surge arrester mounting brackets are provided standard.

Full installation details are provided in the technical manual, this diagram is provided to show a typical arrangement only.

HV Terminal Connectors

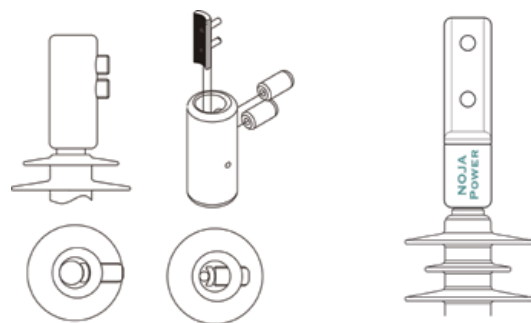

Tunnel Connector

Two Hole NEMA Pad Option

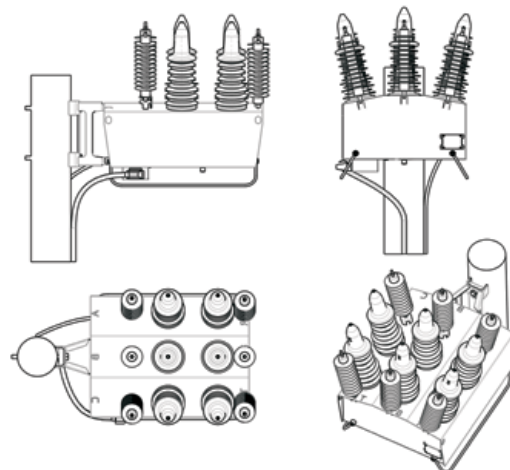

NOJA POWER®

| | |
|--|--------------------------|
| Part Number | OSM38-12-630 |
| Current Sensing | 3 x Current Transformers |
| Voltage Sensing | 6 x Voltage Screens |
| Control Type | RC |
| Rated Maximum Voltage | 38kV |
| Rated Continuous Current | 630A |
| Fault Make Capacity RMS | 12.5kA |
| Fault Make Capacity Peak | 31.5kA |
| Fault Break Capacity | 12.5kA |
| Mechanical Operations | 30,000 |
| Full Load Operations | 30,000 |
| Fault Break Capacity Operations | 200 |
| Short Time Current Withstand | 12.5kA/3 secs |
| Mainly Active Breaking Capacity | 630A |
| Cable Charging Current | 40A |
| Line Charging Current | 5A |
| Impulse Withstand Phase to Ground & Phase to Phase | 195kV |
| Impulse Across the Interrupter | 170kV |
| Power Frequency Withstand Phase to Ground (Dry) | 70kV |
| Across the Interrupter | 70kV |
| Ambient Temperature | -40°C to +55°C |
| Humidity | 0-100% |
| Altitude | 3000M |
| Weight of the Tank | 140kg (309lbs) |

Altitudes above 1000m should be derated in accordance with ANSI C37.60-2003

NOJA Power Switchgear Pty Ltd

16 Archimedes Place, Murarrie,
Qld 4172, Australia

Phone: +61 7 3907 8777
Fax: +61 7 3399 6777
Email: sales@nojapower.com.au
Website: www.nojapower.com

Distributor